

Journal of Soil Sciences and Agricultural Engineering

Journal homepage & Available online at: www.jssae.journals.ekb.eg

The Pump-Power Supplies Performance to Raise the Water from Wells in the Wadi El-Natrun Region

Silim, A. H.¹; Z. E. Ismail¹; N. K. Ismail^{2*} and I. A. Abd El-Rahman¹



Cross Mark

¹ Agriculture Engineering Department, Faculty of Agriculture, Mansoura University, Egypt

² Bio-system Engineering Department, Agricultural engineering research institute (AEnRI), Agricultural research center (ARC), Egypt

ABSTRACT

The problem of the study lies in two directions. The first one is the depletion of fossil energy, which translates into raising the prices of electrical power despite its scarcity in desert areas and new cities. The second is obtaining a sustainable energy source that ensures the efficiency of raising water from the wells during the irrigation period. The study included an evaluation of the performance of six wells in the Wadi El-Natroun region, Beheira Governorate, Egypt, divided into three systems for supplying the energy needed to raise water during the operating period wells, namely Petrol Power (PPS), PV power (PVS), and Hybrid Energy Sources (HES). Data for water well characteristics and initial operating tests were collected from private companies. The evaluation criteria included average discharge and rate of discharge during the test period, hourly and daily discharge rate, and efficiency during the operation period. The study concluded that the average water discharge (AD) for the hybrid system recorded the highest values than that the PPS and PV systems per the interference time of operation. The highest dynamic water level (15.68m) is found at the PPS system of 33.1 min testing time. But, the lowest (8.78m) is found at the HES system under the same times and vice versa with drawdown level decreases.

Keywords: Petrol Power, PV power, Hybrid Energy, Raise water, Drawdown.

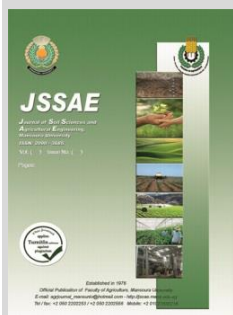

INTRODUCTION

Despite petrol energies contributing to progress over the past several centuries, however, their negative emergence aspects become tangible in various areas of life. The most important of these repercussions is climate change. These are necessitated confronting it in several ways and human practices. The depletion of petrol energy with the increasing demand for energy use, has strapped people to make thoughtful and actual attempts to provide multiple energy sources under the condition that new energies are safe and do not pollute the environment.

It is necessary to increase the efforts in energy provision to face the demand for increasing agricultural area as one of the chief sources of operating and mechanizing farms. It requires increased studies and research to provide an array of energy sources used in all agricultural work stages. Foster et al. (2014) discovered that diesel or conventional-powered electricity is primarily used for water well pumping. Utilizing solar water pumping reduces reliance on electricity generated from coal, gas, or diesel. In addition to requiring costly fuels, water pumping systems that run on propane or diesel also produce noise and air pollution. A diesel pump is two to four times more expensive overall, as well as costlier to operate, maintain, and replace than a solar photovoltaic (PV) pump. Systems for solar pumping are fuel-free, low maintenance, and environmentally benign.

According to Egypt's Solar Atlas (sided from IRENA and FAO, 2021), the country is classified as a sunbelt with 2000–3000 kWh of direct solar radiation per square meter annually and 6-10h of daily sunshine with few cloudy days (Patlitzianas, 2011). Any PV system's design depends on site characteristics such as solar irradiation and the number of hours of sunshine to the temperature. A cabinet, photovoltaic panels, a mechanical

framework, a pump, a pump controller, and cables operate the PV water pumping system (IRENA and FAO, 2021).

Shouman et al. (2018) reported that three distinct systems differ regarding the electrical energy source that powers the water pump. The three water pumping systems are diesel, hybrid PV-Diesel, and only PV. The hybrid PV-Diesel water pumping system, which splits the necessary energy for pumping water between two sources, diesel and photovoltaic cells. The PV water pumping system generates the required electrical energy solely from solar radiation via PV panels during the day. Shouman, et al. (2016) indicated that diesel provides about 22% of the necessary power for the water pump, whereas PV supplies about 78%. Some factors that can affect a water pumping system that uses different technologies, as photovoltaic (PV) or diesel include; location, meteorological conditions, water levels, water demand, and the cost of component replacement, upkeep, and operation. Sharabin (2021) concluded the importance of establishing a solar energy station to use irrigation systems in reclaimed agricultural lands as an alternative to electricity. The hybrid PV-diesel system is necessary in bad weather in the absence of sunlight. These conditions often cause the on-off water pumping system in the PV water pumping system. For this, when water distribution is desired continuously it must external power support is required, and a diesel generator is often used as a backup supply (Kumar, et al. 2016 & Kar et al., 2022). On the other side, Li, et al. (2020) and Bakır, et al. (2023) signed that the water pumping by hybrid system powered is significantly improved the efficiency of the water pumping system. The hybrid irrigation system maximizes the use of PV energy and minimizes diesel consumption (Almeida, 2019). This system makes it particularly adapted in remote and isolated areas. The research conducted by Li, et al. (2020) and Ali and Hamedelnil

* Corresponding author.

E-mail address: nkhismael@gmail.com

DOI: 10.21608/jssae.2024.298744.1235

(2021) recommended that the suitable capacity of pumping water for irrigated about 30 fed was about 37.5% relative to the produced power from the total solar panels of 45 kW, from the solar panels 180 cells.

This research is interested in compare the three different sources of power performance supplying well pumps to raise the water. This aim identifies the average discharge, discharge rate, average dynamic and drawdown water level, hourly and daily well productivity, and the operating water well lifespan.

MATERIALS AND METHODS

The experiment was carried out in Wadi Al-Natron, Al-Buhaira Governorate, on six wells in different regions. Three different power systems were identified to evaluate the operation of a water well: Petrol Power System (PPS), Solar Photovoltaic System (PVS), and Hybrid Energy Sources in the form of Petrol power + PV without Batteries (HES).

The petrol power system (PPS)

It is a communal method to supply electrical power for operating well water pumps (Fig 1). Under the experimental tests, The PPS includes the following main parties: -

- The petrol engine is the Perking P50-403A-15G2 model, having a power of 16.92 kW (23 HP) and needs a fuel consumption of about 6.0 l/h.
- The generator is of Stamford PI044G and has a self-excited system with the man stator that provides power via the AVR to the exciter stator. It includes stator winding of double-layer concentric, the winding pitch of two-thirds, winding leads of 12, and stator WDG. Its resistance of 0.635 Ohms per phase at 22°C series star connected, rotor WDG resistance of 0.551 Ohms, exciter stator resistance of 18.5 Ohms, exciter rotor resistance of 0.228 Ohms per phase at 22°C, and EBS stator resistance of 12.9 Ohms.
- The Control Box is DSE7120 model, an auto mains utility with an icon-based display operated for controlling the electrical flow module. The control module has been designed to control single diesel or gas generator applications. The overall size is 240 mm x 181 mm x 42 mm (9.4" x 6.8" x 1.6"), the panel cutout size is 220mm x 160mm (8.7" x 6.3"), the maximum panel thickness is 8.0mm (0.3"), and the net mass of 0.82kg.

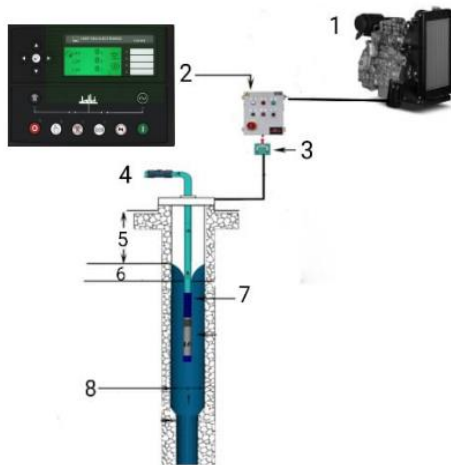

1- Diesel engine 2-Control box 3- Switch 4- Water output
5-Static water level 6. Drawdown 7. Pump 8-Well diameter
Fig. 1. Petrol Power System (PPS) connecting with the water well

PV power system (PVS)

- The PV pumping system (Fig 2) has a PV panels brand Suntech with power from 0.275 to 0.325 kW with the PV

panel dimension 2004 x 1002 x 35 (mm), each having 144 cells in six rows with 24 cells in each row.

- The inverter power is 10-15 HP in a full plug-and-play combiner. The inverter box dimensions are 250 x268 x 42 mm and have a mass of 2.9 kg. The output AC voltage ranges from 183 to 264 V, and the nominal AC voltage is 208, 230, and 240 V. It has a frequency range from 59.3 to 60.5 Hz.
- The controller runs on the pump when the PV array output current reaches a fit operation level and turns it off when the current is lower than that. The pump controller can turn off the pump when the water level in the well is lowered to a certain pre-determined value to avoid the pump's un-wet operation condition. Since the incident solar power keeps on exchanging over the day and also through the seasons, therefore, a regulator is needed to steady the energy output between solar panels and the pumping unit. The controllers include current boosters to fit the current and voltage of the pump.
- Battery types of Eastman Solar ES-100 GEL, made in Vietnam, voltage 12 V (6 cells per unit, dimensions: 330 x 171 x 220 mm, weight of 30.5 kg, cycle life 5:6 years.

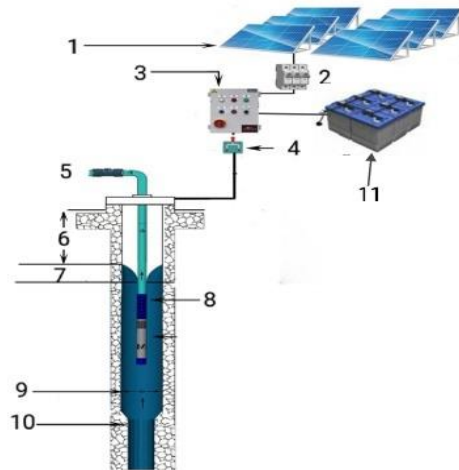

1- PV module 2- DC breaker 3- Control box 4-Switch
5- Water output 6- Static water level 7- Drawdown 8. Pump
9. Well diameter 10- Strainer 11-Batteries
Fig. 2. Solar Photovoltaic System (PVS)

Hybrid Energy Sources (HES)

The hybrid energy sources in the form of Petrol power + PV without Batteries (HES) are in Fig 3. It includes the combination of the above two systems.

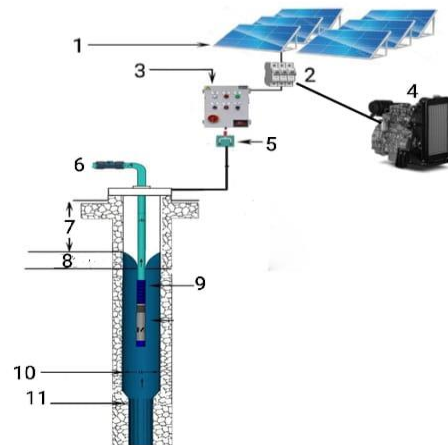

1. PV module 2. DC breaker 3. Control box 4. Engine
5. Switch 6. Water output 7. Static water level
8. Drawdown 9. Pump 10. Well diameter 11. Strainer
Fig. 3. Hybrid energy sources (HES)

The pumps

The specifications of used pump types under the three different energy systems for the wells at the experiment locations are tabulated in Table (1).

Table 1. The specification pumps

Types of power	Types of pumps	Country of manufacture	Pump power (HP)	No. of stages	voltage
PVS	KPS	Türkiye	30	7	220
PPS	KPS	Türkiye	15	5	220
HES	KPS	Türkiye	30	7	220

The experimental procedures: were conducted to define the wells' performance by studying the groundwater properties, and well characteristics, keeping an eye on the level of water. It is also, evaluating the variables of aquifers and wells collected from research institutes for the underground water and irrigation sector belonging to the Ministry of Irrigation and Water Resources, various farms in the Wadi El-Natrun zone, some private companies, and the data that survey at the operation used for the studied zone from seasons 2021 to 2023.

Firstly, the surveying zones of the study areas were set at 30.33 °E and 30.58 °N. Secondly, considerations must be taken into account when choosing the type and placement of photovoltaic cells in the study area to obtain the highest efficiency, which as; site parameters such as solar irradiance number of sunlight hours, and ambient temperatures. Then the studied properties and the evaluation of the three systems for supplying the energy needed to raise water (PPS, PVS, and HES) during the operating period wells. The drip irrigation systems are widely in the experimental region used and the olive trees are the planting field.

The evaluations include the following parameters

Discharge and discharge rate

It refers to the volume of water flowing through a particular point in a water system over a specified period. In the well, the discharge rate at which water flows out of the well is typically measured in m³/h. A tank of known volume was turned on the pump until the tank was filled. The Eq. (1) was used to calculate the discharge for each well:

$$Q = \frac{v}{t} \tag{1}$$

Where: v: is the volume, m³ and "t" is time, h.

The dynamic water level

The total head of dynamic water level (TDH) refers to the total energy per unit of fluid mass at the inlet and outlet of a pump system. It represents the total pressure and elevation head that the pump must overcome to move fluid from its source to its destination. The TDH equation (2) can expressed as the following equation:

$$TDH = H_s + D_d \tag{2}$$

Where:

- H_s: the static water level, m
- D_d: the drawdown, m

Then,

$$\text{Drawdown level} = TDH - H_s \tag{3}$$

The productivity of the well during its operating period can be calculated by applying the Eq. (4):

$$P = Q \times A \times B \times C \tag{4}$$

Where:

- P: the productivity, m³
- Q: well discharge rate, m³/h
- A: the number of operating hours per day h,
- B: number of operating days per year, day,
- C: the number of years of operation of the well

Pumping efficiency

The pump efficiency is the ratio between the hydraulic power used to pump a volume of water through a given height of the system output power. The pump's hydraulic output can be calculated according to the formula (5):

$$HP = \rho gQH \tag{5}$$

Where:

- HP: hydraulic power output of the pump, W
- H: the monomeric head, m
- Q: the output flow rate of the pump, m³/h
- P: density of water, g/cm³
- G: gravity of acceleration (9.81 m/s²)

$$\text{Pump efficiency} = \frac{HP}{APO} \times 100$$

Where:

- HP: hydraulic power, W
- APO: array power output, W

Total (system) efficiency is including the relation between the hydraulic power and the input power (HP and API) as Eq. (6):

$$\text{System efficiency} = \frac{HP}{API} \times 100 \tag{6}$$

Where:

- API: array power input, W

Mathematical analyses

The regression equations of discharge rates, dynamic water level, drawdown, and the system's efficiency were determined for the three power systems applied in the study.

RESULTS AND DISCUSSION

Comparing the power sources on wells performance at test stages

1-The average discharge (AD) and discharge rate (ADR)

The performance evaluation of three different water pumping systems (PPS, PVS, and HES) is illustrated as shown in Fig 4. Each system's cumulative water discharge curves are proportional to their operating times. The discharge calculation is performed after 20 minutes of startup to compensate for any water flow disturbance that may occur when the pump starts.

The average of water discharge (AD) under the PPS system (Fig 4) is recorded at 63.33, 61.67, and 50.00 m³ per interference time (from 22.06 to 25.74min), (from 25.74 to 29.42 min), and (from 29.42 to 33.1min), respectively. For hybrid HES, the AD recorded 90, 60, and 50 m³ per interference time (from 22.06 to 25.74min), (from 25.74 to 29.42 min), and (from 29.42 to 33.1min), respectively. But for PVS sole, the AD values are 70, 35, and 30 m³ per interference time (from 22.06 to 25.74min), (from 25.74 to 29.42 min) and (from 29.42 to 33.1min), respectively.

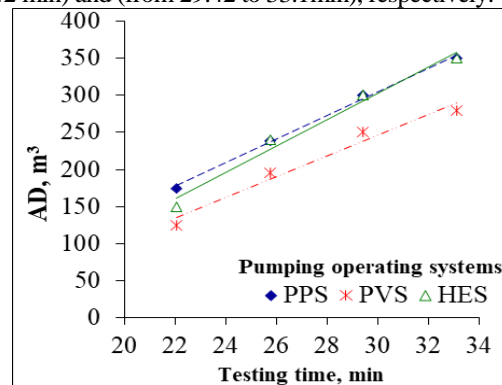

Fig. 4. The average of water discharge (AD) relative to operating time periods

On the other hand, the average discharge rates (ADR) in Fig (5) are 17.21, 22.76, and 13.59 m³/min per different depreciation for an average of 17.85 m³/min under the PPS system. But for the HES system, the ADR is recorded at 19.23, 22.35, and 13.59 m³/min with an average of 18.39 m³/min. While at the PV solo, the ADR is 14.96, 13.06, and 8.15 m³/min for an average of 12.06 m³/min, respectively. So, the HES is the best because it recorded the maximum discharge per unit time.

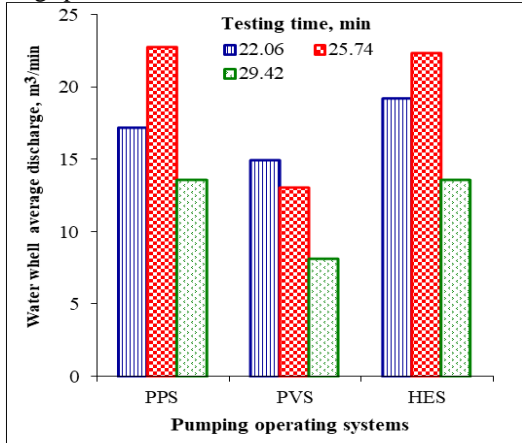

Fig. 5. The pumping operating system via the average of well discharging rate

The average discharge rates for all experiments under operating the water well were as in the following equation;

$$ADR, m^3 = -0.6793T^2 + 34.981T - 427.55 \text{ at PPS} \quad 7$$

$$ADR, m^3 = -0.1111T^2 + 4.7958T - 36.754 \text{ at PVS} \quad 8$$

$$ADR, m^3 = -0.4386T^2 + 21.814T - 248.53 \text{ at HES} \quad 9$$

From Eq. 7 to 9, the ADR relative operating time equations designated the ADR maximum were at operating time of 24.98, 21.82, and 25.36 min giving 17.85, 14.81, and 18.39 m³ respectively for PPS, PVS, and HES. Then the highest average of the ADR is at HES and the lowest at PVS, this results because the HES system gives a continuity of energy to the water well.

2- The average dynamic water level (ADWL, m)

The cumulative curves for the average of dynamic water level (ADWL, m) per testing time under the three systems are directly proportional to the operating time (Fig 6). The ADWL increased by about 1.52, 1.47, and 1.47 times at an increase in the test time of 1.5 times. The change values of the ADWL per time are close to each other for HES and PV systems and wide to each other for the PPS systems. The highest dynamic water level (15.68m) is at the PPS system under 33.1 min testing time. But, the lowest (8.78m) under the same times is at the HES system. A simple correlation was carried out to examine the nature of the relationship between the ADWL and testing operating time. The statistical analysis is related to the following formulas;

$$ADWL, m = 0.4880 T - 0.4032 \quad R^2 = 0.9991 \quad \text{at PPS} \quad 10$$

$$ADWL, m = 0.3933 T + 0.0648 \quad R^2 = 0.9904 \quad \text{at PVS} \quad 11$$

$$ADWL, m = 0.3736 T + 0.783 \quad R^2 = 0.9954 \quad \text{at HES} \quad 12$$

It is interesting to note out of Eq. from 10 to 12 that both the PVS and HES systems are nearly close for the sloping angles of the inclination relation lines (22.66 and 21.44 degrees). But the PPS is wide with sloping angles of 28.66 degrees. That fact that this trend is achieved and explaining more power and more dynamic water level (head pressure).

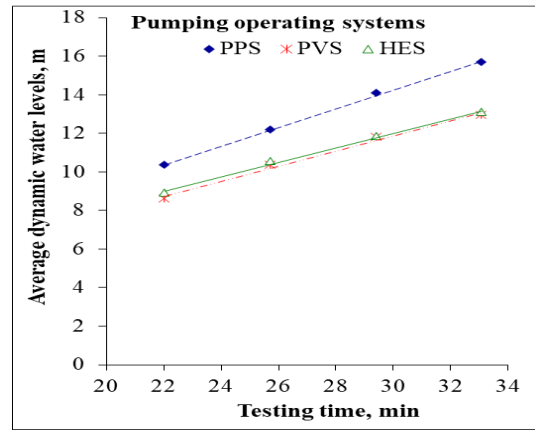

Fig. 6. The operating testing time via the average of dynamic water level

3- The average drawdown (ADD, m)

The cumulative curves for the average drawdown (ADD, m) per testing time under the three systems are directly proportional in the down with operating time (Fig 7). The average drawdown (ADD, m) increased by about 2.34, 2.91, and 2.86 times at an increase in the test time of 1.5 times. The change values of the ADD per time are down increased from 3.99 to 9.34 m, from 2.28 to 6.30, and from 2.01 to 5.74 m for PPS, HES, and PV systems, respectively. It is interesting to note that increasing the drawdown level decreases the free water level in the well. So, the best system is PVS because it records the lowest drawdown.

A simple correlation was carried out to examine the nature of the relationship between the ADWL and testing operating time. The statistical analysis is related to the following formulas;

$$ADD = 0.4876T - 6.7429 \quad R^2 = 0.9992 \quad \text{PPS} \quad 13$$

$$ADD = 0.3933T - 6.2369 \quad R^2 = 0.9905 \quad \text{PVS} \quad 14$$

$$ADD = 0.3383T - 5.2509 \quad R^2 = 0.9784 \quad \text{HES} \quad 15$$

It is normal to note out of Eq. (10, 11, and 12) and Eq. (13, 14, and 15) that both groups were complement each other. It means that increasing the average dynamic water level decreases the average drawdown (ADD, m) with the same ratio, that appears during comparing the slop lines angles as shown in Fig 6 (28.66, 22.66, and 21.44 degrees) and Fig 7 (28.66, 22.93, and 19.49 degrees). The fact that this trend is achieved may explain and prove the theoretical basis of the relationship between the dynamic water level and water well drawdown.

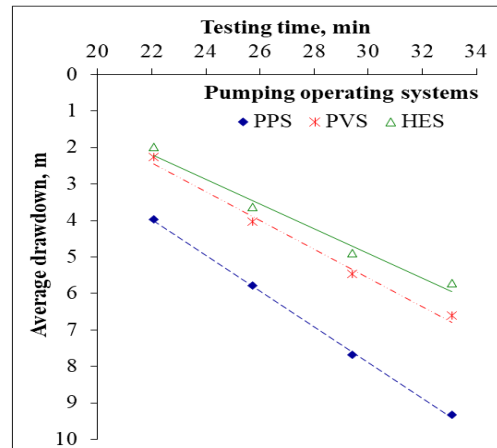

Fig. 7. The pumping operating testing time via the average drawdown (ADD, m)

Well operational performance under different pumping operating systems

1- Hourly discharge (HD, m³/h)

Generally, the energy generated using the PVS and the HES varies with the amount of light radiation. Therefore, the energy values entering the pumps differ, and to stabilize that energy, a regulator or an electrical controlling system must be added. Under this experiment section, the pumping operating systems were carried out without using the electrical controlling cycles. The interaction amount of water well discharge at the beginning operating system (7 AM) was recorded at 140, 90, and 95 m³/h under the different pumping operating systems of PPS, HES, and PVS, respectively (Fig 8). The hourly discharge (HD) for water well before and after noon in the hybrid system (Fig 8) decreased because the system did not load to work as a hybrid system during those periods. Whereas through those periods irrigation is not done.

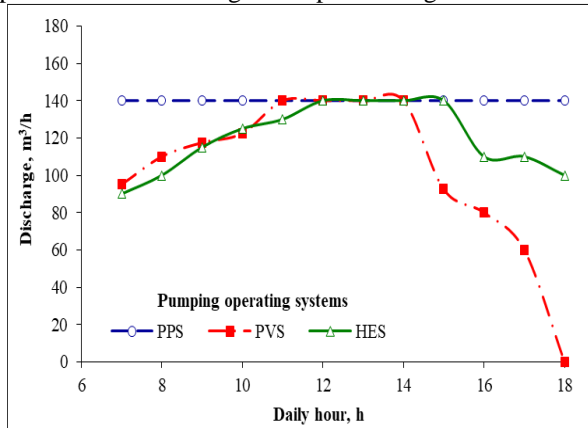

Fig. 8. Hourly discharge for water wells under different pumping operating systems

2. Daily discharge (DD, m³/day)

The daily discharge rate of water wells operating under different pumping operating systems is illustrated in Fig 9. The amounts of DD were 1680.0, 1237.5 and 1440.0 m³/day respectively for PPS, PVS, and HES. The standard deviation of daily discharge (DD, m³/day) were ±0.00, ±41.86 and ±18.22 for PPS, PVS, and HES, respectively. The daily discharge rate of water wells operating decreased in the PVS system by about 26.34% compared with the PPS system. The decrease in daily discharge rate in the HES system was about 14.29% compared to the PPS system (Fig 9).

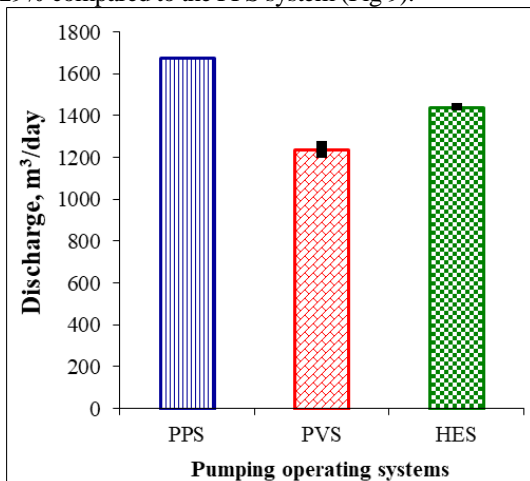

Fig. 9. The daily discharge rate of water wells operating under different power systems

3. The operating of water well lifespan

The comparison efficiency for the PPS, PVS and HES operating efficiency is illustrated in Fig (10). The life without a system overhaul (giant maintenance) for PVS and HES power systems is up to 25 years against 10 or 15 years for PPS. Otherwise, the rates of decline in the discharge reduction from the end of the life span to the beginning of operation were 71.43, 68.75, and 72.2% for 70, 100, and 150 m³/h discharge rates, respectively, for the PVS system.

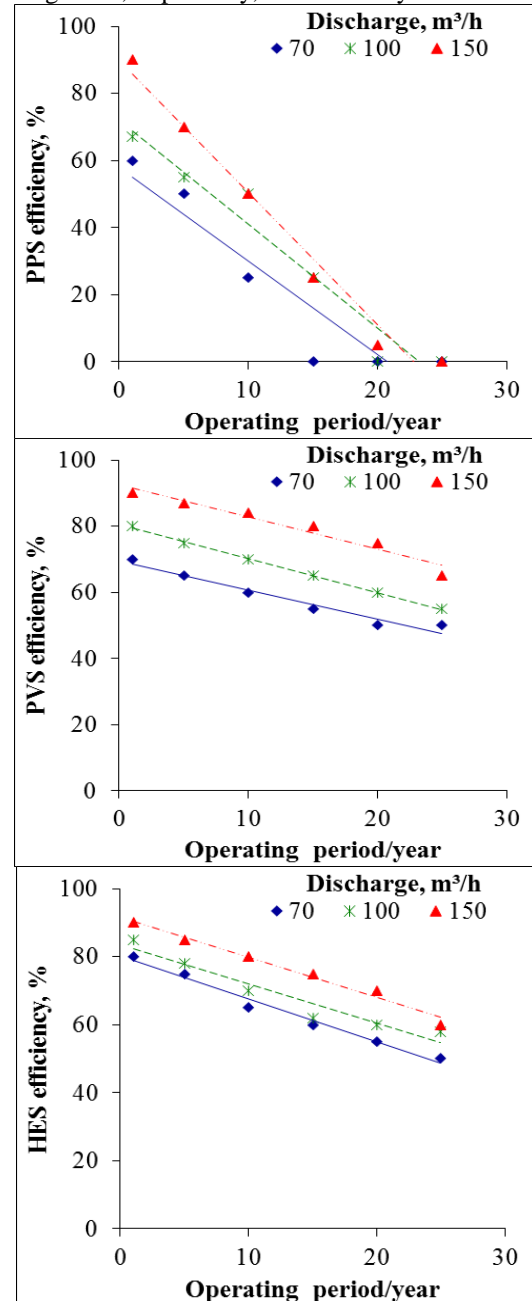

Fig. 10. The reduction rate efficiency (RRE, %)

However, the discharge reduction rates for the Diesel operating were 41.67, 37.31, and 5.55% per 70, 100, and 150 m³/h discharge rate, respectively. Moreover, the discharge reduction rates for the Hybrid energy system were 81.25, 72.94, and 77.78% per 70, 100, and 150 m³/h discharge rate, respectively. The equations that describe the reduction rate efficiency (RRE, %) relative to the operation periods (OP, year) are;

The PVS systems	The diesel system (PPS)	The HES systems
RRE, % = -0.879 OP + 69.468 R ² = 0.96 at 70 m ³ /h	RRE, % = -2.7823OP + 57.742 R ² = 0.87 at 70 m ³ /h	RRE, % = -1.2621OP + 80.153 R ² = 0.98 at 70 m ³ /h
RRE, % = -1.028 OP + 80.524 R ² = 0.998 at 100 m ³ /h	RRE, % = -3.0927OP + 72.008 R ² = 0.948 at 100 m ³ /h	RRE, % = -1.1524 OP + 83.431 R ² = 0.93 at 100 m ³ /h
RRE, % = -0.974 OP + 92.506 R ² = 0.9456 at 150 m ³ /h	RRE, % = -3.9315OP + 89.798 R ² = 0.975 at 150 m ³ /h	RRE, % = -1.1774 OP + 91.581 R ² = 0.98 at 150 m ³ /h

The reduction rate efficiency (RRE, %) recorded the inverse relationship with the operating period (OP), by increasing the OP the RRE decreases under the PVS and PPS systems and vice versa for the relationship of water well discharge with the operation period on the RRE. The efficiency of decreasing rate for the PPS system is higher than that for the PVS system. From the above equations, the negative sine indicates the inversely relation was found. The sloping degree of the curves described the RRE with the OP were 39.61, 31.06, and 34.15 under 70, 100, and 150 m³/h respectively, for PVS, were 17.65, 23.94, and 22.51 under 70, 100, and 150 m³/h respectively, for HES and were 20.50, 42.71, and 44.63, respectively, for the PPS diesel efficiency.

CONCLUSION

The study concluded that the average water discharge (AD) for the hybrid HES recorded the highest values than that for the PPS and PV systems per the same interference time of operation. So, the HES is the best for the average discharge rate because it records the maximum discharge per unit time. The highest dynamic water level (15.68m) is at the PPS system under 33.1 min testing time. But, the lowest (8.78m) is at the HES system under the same condition, and vice versa for the drawdown level decreasing.

REFERENCES

- Ali, O. Z. M. and M. I. Hamedelnil (2021). Solar water pump designing. Humanitarian & Natural Sciences Journal (HNSJ) ISSN: (e) 2709-0833 www.hnjjournal.net Volume 2, Issue 4, 90-102.
- Almeida, R. H. (2019). Large power hybrid PV Pumping for irrigation. PHD Thesis, Universidade and De Lisboa, Faculdade De CIÊNCIAS.
- Bakır, H.; A. Merabet and M. Kiehadrouinezhad (2023). Optimized control of a hybrid water pumping system integrated with solar photovoltaic and battery storage: Towards sustainable and green water-power supply. Energies, 16, 5209. <https://doi.org/10.3390/16135209>. <https://www.mdpi.com/journal/energies>.

- Shouman, E. R.; E. T. El Shenawy; M. A. Badr (2016). Economics analysis of diesel and solar water pumping with case study water pumping for irrigation in Egypt. International Journal of Applied Engineering Research, 11 (2), 950-954.
- IRENA and FAO (2021). Renewable energy for agri-food systems – Towards the Sustainable Development Goals and the Paris agreement. Abu Dhabi and Rome. <https://doi.org/10.4060/cb7433en>.
- Kar, B. N.; P. Samuel; J. K. Pradhan and A. Mallick (2022). Grid-connected solar photovoltaic-fed brushless DC motor drive for water pumping system using colliding body optimization technique. Circuit World, ahead of print.
- Kumar, R. and B. Singh (2016). Solar PV-battery based hybrid water pumping system using BLDC motor drive. In Proceedings of the 2016 IEEE 1st International Conference on Power Electronics, Intelligent Control and Energy Systems (ICPEICES), Delhi, India, 4–6 July; pp. 1–6.
- Li, D.; D. Zhu; R. Wang; M. Ge; S. Wu and Y. Cai (2020). Sizing Optimization and Experimental Verification of a Hybrid Generation Water Pumping System in a Greenhouse. Hindawi, Mathematical Problems in Engineering, Volume 2020, Article ID 3194196, 11 pages <https://doi.org/10.1155/2020/3194196>.
- Foster, R.; G. Majid and A. Cota (2014). A test book of solar energy. Renew Energy; www.amazon.com/Solar-Energy-Renewable-Environmen.
- Patlitzianas, K. D. (2011). Solar energy in Egypt: Significant business opportunities. Renewable energy, 36 (9), 2305-2311.
- Sharabin, E. M. (2021). An economic study for the use of Solar energy in the irrigation of reclaimed agricultural lands in Assiut Governorate. Egypt. J. Agric. Res., 99 (3), 354-378.
- Shouman, E. R., Ezz, H. and Bakhom, E. S. (2018). Economic analysis of the using of traditional fuel and solar energy to power irrigation pumps in Egypt. International Journal of Engineering Research in Africa, Trans Tech Publications Ltd, Vol. 38, pp. 87-99.

إمدادات الطاقة للمضخات لرفع المياه من الآبار في منطقة وادي النطرون

أحمد حماده سليم¹، زكريا إبراهيم إسماعيل¹، ناهد خيرى إسماعيل² و إسلام عاطف عبد الرحمن¹

¹ قسم الهندسة الزراعية، كلية الزراعة، جامعة المنصورة، مصر

² قسم بحوث هندسة النظم الحيوية الزراعية، معهد بحوث الهندسة الزراعية، مركز البحوث الزراعية، مصر

المخلص

تكمن مشكلة الدراسة في محورين الأول وهو نضوب الطاقة الأحفورية وارتفاع أسعار الطاقة الكهربائية مع ندرة توفرها في المناطق الصحراوية والمدن الجديدة. والثاني الحصول على مصدر طاقة مستدام يضمن كفاءة رفع المياه من الآبار بصورة منتظمة خلال فترات الري المطلوبة. مما يستوجب التوجه إلى استخدام الطاقات الجديدة. لذا يهدف هذا البحث إلى مقارنة ثلاث مصادر لإمداد مضخات رفع المياه بالطاقة. وقد اشتملت الدراسة على تقييم أداء ستة آبار في منطقة وادي النطرون، محافظة البحيرة، مصر، مقسمة إلى ثلاث أنظمة للإمداد بالطاقة اللازمة لرفع المياه (الطاقة البترولية "PPS"، الطاقة الكهروضوئية "PV"، النظام الهجين "HES") "الطاقة الكهروضوئية + الطاقة البترولية". وقد تم تجميع بيانات وخصائص الآبار والاختبارات الأولية للتشغيل من الشركات الخاصة. وقد تضمنت معايير التقييم: متوسط ومعدل التصريف خلال فترة الاختبار، ومعدل التصريف في الساعة واليومى والكفاءة خلال فترة التشغيل. وخلصت الدراسة إلى أن متوسط تصريف المياه (AD) لنظام HES الهجين سجل أعلى القيم من نظامي الطاقة PPS و PV في نفس زمن التشغيل. كما أن أعلى مستوى ديناميكي للمياه (15.68 م) سجل مع نظام PPS في أقل من 33.1 دقيقة من وقت الاختبار. لكن أقل قيمة (8.78م) سجل مع نظام HES في نفس الأوقات والعكس مع انخفاض مستوى السحب.